

# Pharos Specification

## Table of Contents

Objectives / Scope	1
A Pharos compliant OPNFV test-bed environment provides	1
Hardware requirements	2
Provisioning the jump server	2
Remote management	3
Networking	4
Architecture	5
Sample Network Drawings	6

## Objectives / Scope

The Pharos specification defines the OPNFV hardware environment upon which the OPNFV Arno platform release can be deployed on and tested. This specification defines:

- A secure, scalable, standard and HA environment
- Supports the full Arno deployment lifecycle (this requires a bare metal environment)
- Supports functional and performance testing of the Arno release
- Provides mechanisms and procedures for secure remote access to the test environment

Deploying Arno in a Virtualized environment is possible and will be useful, however it does not provide a fully featured deployment and test environment for the Arno release of OPNFV.

The high level architecture is outlined in the following diagram:

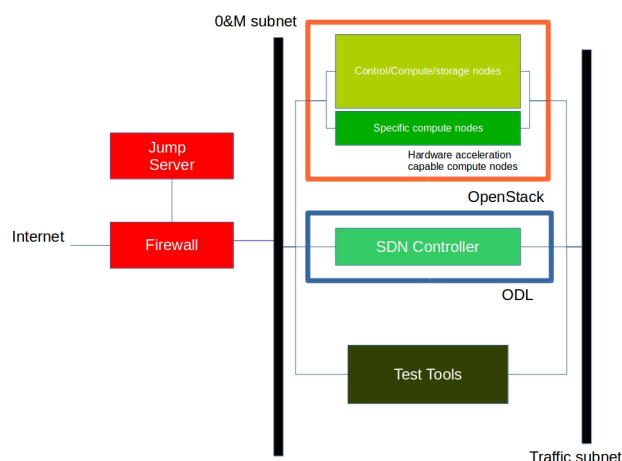

## A Pharos compliant OPNFV test-bed environment provides

- One CentOS 7 jump server on which the virtualized Openstack/OPNFV installer runs

- In the Arno release you may select a deployment toolchain to deploy from the jump server from the Foreman and Fuel ISO images.
- 5 compute / controller nodes ([BGS](#) requires 5 nodes)
- A configured network topology allowing for LOM, Admin, Public, Private, and Storage Networks
- Remote access as defined by the Jenkins slave configuration guide <http://artifacts.opnfv.org/arno.2015.1.0/docs/opnfv-jenkins-slave-connection.arno.2015.1.0.pdf>

## Hardware requirements

### Servers

#### CPU:

- Intel Xeon E5-2600v2 Series (Ivy Bridge and newer, or similar)

#### Local Storage Configuration:

Below describes the minimum for the Pharos spec, which is designed to provide enough capacity for a reasonably functional environment. Additional and/or faster disks are nice to have and may produce a better result.

- Disks: 2 x 1TB + 1 x 100GB SSD
- The first 1TB HDD should be used for OS & additional software/tool installation
- The second 1TB HDD configured for CEPH object storage
- Finally, the 100GB SSD should be used as the CEPH journal
- Performance testing requires a mix of compute nodes that have CEPH(swift+Cinder) and without CEPH storage
- Virtual ISO boot capabilities or a separate PXE boot server (DHCP/tftp or Cobbler)

#### Memory:

- 32G RAM Minimum

#### Power Supply Single

- Single power supply acceptable (redundant power not required/nice to have)

## Provisioning the jump server

1. Obtain CentOS 7 Minimal ISO and install

```
wget
```

```
http://mirrors.kernel.org/centos/7/isos/x86_64/CentOS-7-x86_64-Minimal-1503-01.iso
```

2. Set parameters appropriate for your environment during installation

3. Disable NetworkManager

```
systemctl disable NetworkManager
```

4. Configure your /etc/sysconfig/network-scripts/ifcfg-\* files for your network

5. Restart networking

```
service network restart
```

6. Edit /etc/resolv.conf and add a nameserver

```
vi /etc/resolv.conf
```

7. Install libvirt & kvm

```
yum -y update yum -y install kvm qemu-kvm libvirt systemctl enable libvirtd
```

8. Reboot:

```
shutdown -r now
```

9. If you wish to avoid annoying delay when use ssh to log in, disable DNS lookups:

```
vi /etc/ssh/sshd_config Uncomment "UseDNS yes", change 'yes' to 'no'. Save
```

10. Restart sshd

```
systemctl restart sshd
```

11. Install virt-install

```
yum -y install virt-install
```

12. Begin the installation of the Arno release

Download your preferred ISO from the [OPNFV downloads page](#) and follow the associated installation instructions.

## Remote management

### Remote access

- Remote access is required for ...
  1. Developers to access deploy/test environments (credentials to be issued per POD / user)
  2. Connection of each environment to Jenkins master hosted by Linux Foundation for automated deployment and test
- OpenVPN is generally used for remote however community hosted labs may vary due to company security rules
- POD access rules / restrictions ...
  - Refer to individual test-bed as each company may have different access rules and acceptable usage policies
- Basic requirement is for SSH sessions to be established (initially on jump server)
- Majority of packages installed on a system (tools or applications) will be pulled from an external repo so this scenario must be accomodated.

Firewall rules should include

- SSH sessions
- Jenkins sessions

Lights-out Management:

- Out-of-band management for power on/off/reset and bare-metal provisioning
- Access to server is through lights-out-management tool and/or a serial console
- Intel lights-out ⇒ RMM <http://www.intel.com/content/www/us/en/server-management/intel-remote-management-module.html>
- HP lights-out ⇒ ILO <http://www8.hp.com/us/en/products/servers/ilo/index.html>
- CISCO lights-out ⇒ UCS <https://developer.cisco.com/site/ucs-dev-center/index.gsp>

Linux Foundation - VPN service for accessing Lights-Out Management (LOM) infrastructure for the UCS-M hardware

- People with admin access to LF infrastructure:

1. [amaged@cisco.com](mailto:amaged@cisco.com)
2. [cogibbs@cisco.com](mailto:cogibbs@cisco.com)
3. [daniel.smith@ericsson.com](mailto:daniel.smith@ericsson.com)
4. [dradez@redhat.com](mailto:dradez@redhat.com)
5. [fatih.degirmenci@ericsson.com](mailto:fatih.degirmenci@ericsson.com)
6. [fbrockne@cisco.com](mailto:fbrockne@cisco.com)
7. [jonas.bjurel@ericsson.com](mailto:jonas.bjurel@ericsson.com)
8. [jose.lausuch@ericsson.com](mailto:jose.lausuch@ericsson.com)
9. [joseph.gasparakis@intel.com](mailto:joseph.gasparakis@intel.com)
10. [morgan.richomme@orange.com](mailto:morgan.richomme@orange.com)
11. [pbandzi@cisco.com](mailto:pbandzi@cisco.com)
12. [phladky@cisco.com](mailto:phladky@cisco.com)
13. [stefan.k.berg@ericsson.com](mailto:stefan.k.berg@ericsson.com)
14. [szilard.cserey@ericsson.com](mailto:szilard.cserey@ericsson.com)
15. [trozet@redhat.com](mailto:trozet@redhat.com)

- The people who require VPN access must have a valid PGP key bearing a valid signature from one of these three people. When issuing OpenVPN credentials, LF will be sending TLS certificates and 2-factor authentication tokens, encrypted to each recipient's PGP key.

## Networking

### Test-bed network

- 24 or 48 Port TOR Switch
- NICS - 1GE, 10GE - per server can be on-board or PCI-e
- Connectivity for each data/control network is through a separate NIC. This simplifies Switch Management however requires more NICs on the server and also more switch ports
- Lights-out network can share with Admin/Management

### Network Interfaces

- Option I: 4x1G Control, 2x40G Data, 48 Port Switch
  - 1 x 1G for ILMI (Lights out Management )
  - 1 x 1G for Admin/PXE boot
  - 1 x 1G for control Plane connectivity
  - 1 x 1G for storage
  - 2 x 40G (or 10G) for data network (redundancy, NIC bonding, High bandwidth testing)
- Option II: 1x1G Control, 2x 40G (or 10G) Data, 24 Port Switch
  - Connectivity to networks is through VLANs on the Control NIC. Data NIC used for VNF traffic and storage traffic segmented through VLANs
- Option III: 2x1G Control, 2x10G Data, 2x40G Storage, 24 Port Switch
  - Data NIC used for VNF traffic, storage NIC used for control plane and Storage segmented through VLANs (separate host traffic from VNF)
  - 1 x 1G for IPMI

- 1 x 1G for Admin/PXE boot
- 2 x 10G for control plane connectivity/Storage
- 2 x 40G (or 10G) for data network

Documented configuration to include: - Subnet, VLANs (may be constrained by existing lab setups or rules) - IPs - Types of NW - lights-out, public, private, admin, storage - May be special NW requirements for performance related projects - Default gateways

Controller node bridge topology overview

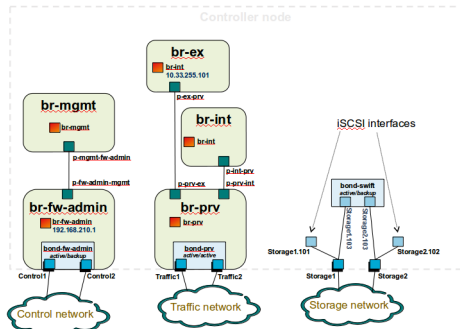

compute node bridge topology overview

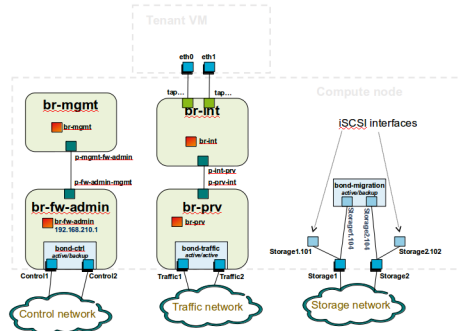

## Architecture

\*\* Network Diagram \*\*

The Pharos architecture may be described as follow: Figure 1: Standard Deployment Environment

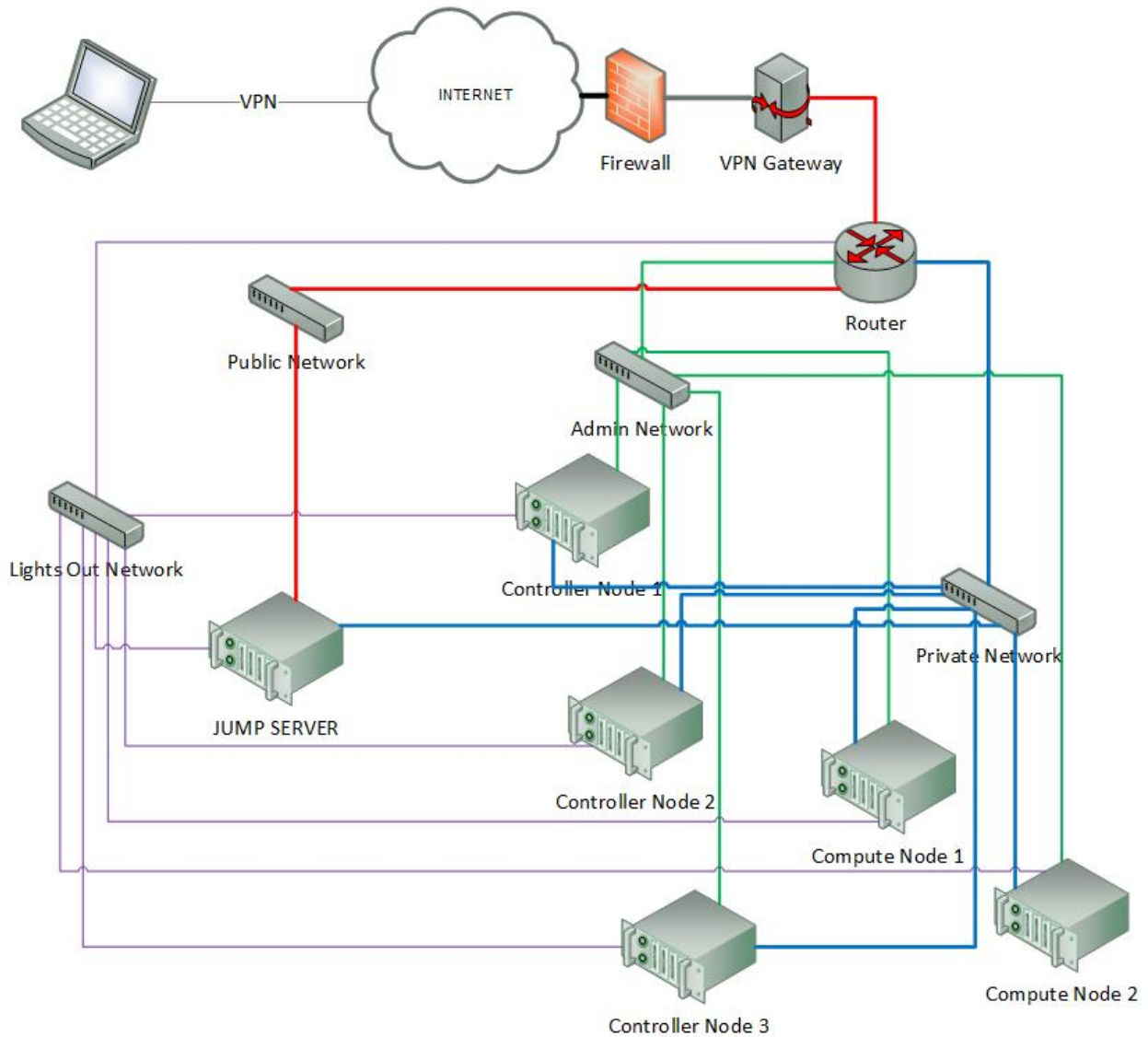

Figure 1: Standard Deployment Environment

## Sample Network Drawings

Files for documenting lab network layout. These were contributed as Visio VSDX format compressed as a ZIP file. Here is a sample of what the visio looks like.

Download the visio zip file here: [opnfv-example-lab-diagram.vsd.zip](http://opnfv-example-lab-diagram.vsd.zip)

