



**Parser Project**  
*Release draft (1a0bd86)*

**OPNFV**

August 22, 2016



<b>1</b>	<b>Introduction of Parser Project</b>	<b>1</b>
<b>2</b>	<b>Parser YANG2TOSCA</b>	<b>3</b>
2.1	Overview . . . . .	3
2.2	Prerequisites . . . . .	3
2.3	Installation . . . . .	3
2.4	Execution . . . . .	4
<b>3</b>	<b>New Parser keywords</b>	<b>5</b>
3.1	1.NFV-tosca new keywords . . . . .	5
3.2	2.Simple-tosca new keywords . . . . .	6
<b>4</b>	<b>1. vRNC Topology</b>	<b>9</b>
4.1	2. vRNC Definition . . . . .	10



## INTRODUCTION OF PARSER PROJECT

In NFV, various templates (such as descriptors, records and so on) are utilized to describe the deployment requirements (such as basic VM requirements – vCPU, memory, storage, as well as the NFV acceleration management requirement such as Huge Pages support, SR-IOV, NUMA affinity, DPDK support etc.), the post-instantiation records (such as storage usage report, CPU performance report etc.) or other purposes. However in order to make these templates adaptable and feasible for purpose like deployment orchestration/automation, certain tooling mechanism that provides template translation is necessary.

Project Parser will help to provide such tooling mechanism, by parsing Telecom operators' descriptors/records into TOSCA/CAMP templates and then further translate TOSCA/CAMP templates into certain common templates, which could be used in IaaS orchestration projects like OpenStack Heat.

For Release B, Parser offers the following capabilities:

- Integration of Heat-Translator Liberty release code. (both heat in-tree code and standalone package are provided)
- Yang2Tosca module which offers the capability to translate yang based scriptors to tosca formate templates. Users could further use Heat-translator module to translate this tosca template to Heat Orchestration template. Yang2Tosca module could be installed seperately after user installed OPNFV B release platform.
- The “parser\_new\_keywords” document demonstrate a set of keywords concluded by Parser team that need to be supported in tosca to heat translation. However it should be noted that these keywords only serve as a roadmap. We will start from Release C to indicate which specific set of keywords are supported in Parser.
- The “vRNC\_tosca\_intro” document describes Parser’s use case analysis on vRNC scenario. The “example” folder contains examples of tosca-nfv standard and vRNC scenario. See also <https://wiki.opnfv.org/parser> .



## PARSER YANG2TOSCA

### 2.1 Overview

Parser is an open source project and licensed under Apache 2. Parser will help to provide a tooling mechanism, by parsing Telecom operators' VNF descriptors (YANG templates) into TOSCA templates and then further translate TOSCA templates into certain common templates, which could be used in IaaS orchestration projects like OpenStack Heat.

### 2.2 Prerequisites

Parser requires the following to be installed.

#### 2.2.1 1. PYANG

Please follow the below installation steps.

Step 1: Clone pyang tool or download the zip file from the following link.

```
git clone https://github.com/mbj4668/pyang.git
```

OR

```
wget https://github.com/mbj4668/pyang/archive/master.zip
```

Step 2: Change directory to the downloaded directory and run the setup file.

```
cd pyang
python setup.py
```

#### 2.2.2 2. python-lxml

Please follow the below installation link. <http://lxml.de/installation.html>

### 2.3 Installation

Please follow the below installation steps to install parser.

Step 1: Clone the parser project.

```
git clone https://gerrit.opnfv.org/gerrit/parser
```

## 2.4 Execution

Step 1: Change directory to where the scripts are present.

```
cd parser/yang2tosca
```

**Step 2: Copy the YANG file which needs to be converted into TOSCA to** current (parser/yang2tosca) folder.

Step 3: Run the python script “parser.py” with the YANG file as an input option.

```
python parser.py -n "YANG filename"
```

Example:

```
python parser.py -n example.yaml
```

**Step 4: Verify the TOSCA YAMI which file has been created with the same name** as the YANG file with a “\_tosca” suffix.

```
cat "YANG filename_tosca.yaml"
```

Example:

```
cat example_tosca.yaml
```



## NEW PARSER KEYWORDS

### 3.1 1.NFV-tosca new keywords

All keywords in nfv toasca are not implemented in code, and will be implemented by parser.

#### 3.1.1 1.1 Nodes types

##### Basic types

- `tosca.nodes.nfv.VDU`
- `tosca.nodes.nfv.CP`
- `tosca.nodes.nfv.VL`

##### Extend types

- `tosca.nodes.nfv.VL.ELine`
- `tosca.nodes.nfv.VL.ELAN`
- `tosca.nodes.nfv.VL.ETree`
- `tosca.nodes.nfv.FP`

#### 3.1.2 1.2 Capability types

##### Basic types

- `tosca.capabilities.nfv.VirtualBindable`
- `tosca.capabilities.nfv.VirtualLinkable`
- `tosca.capabilities.nfv.HA.ActiveActive`
- `tosca.capabilities.nfv.HA.ActivePassive`
- `tosca.capabilities.nfv.Metric`

## Extend types

- `tosca.capabilities.nfv.Forwarder`
- `tosca.capabilities.nfv.CPU_extension`
- `tosca.capabilities.nfv.Memory_extension`
- `tosca.capabilities.nfv.Hypervisors`
- `tosca.capabilities.nfv.PCIe`
- `tosca.capabilities.nfv.network.Interfaces`
- `tosca.capabilities.nfv.network.Virtual_switches`
- `tosca.capabilities.nfv.Storage`

### 3.1.3 1.3 Relationship types

#### Basic types

- `tosca.relationships.nfv.VirtualBindsTo`
- `tosca.relationships.nfv.VirtualLinksTo`
- `tosca.relationships.nfv.HA`
- `tosca.relationships.nfv.Monitor`

#### Extend types

- `tosca.relationships.nfv.ForwardsTo`

### 3.1.4 1.4 Group Types

- `tosca.groups.nfv.VNFFG`

## 3.2 2.Simple-tosca new keywords

Some keywords are only defined in toasca simple profile, but are not supported in toasca-paser, and some keywords such as “policy type”, are not yet defined completely so far.

### 3.2.1 2.1 topology template keyname

- “substitution\_mappings” syntax

An optional declaration that exports the topology template as an impletmentation of a node type, which is not supported by toasca-parser.

### 3.2.2 2.2 Group types

#### Basic types

- `tosca.group.root`

### 3.2.3 2.3 Policy Types

#### Basic types

- `tosca.policies.Root`
- `tosca.policies.Placement`
- `tosca.policies.Scaling`

#### Extend types

- `tosca.policies.Update`
- `tosca.policies.Performance`
- `tosca.policy.placement.Antilocate`
- `tosca.policy.placement.Colocate`



## 1. VRNC TOPOLOGY

The simple vRNC topology is shown below: Fig. 4.1

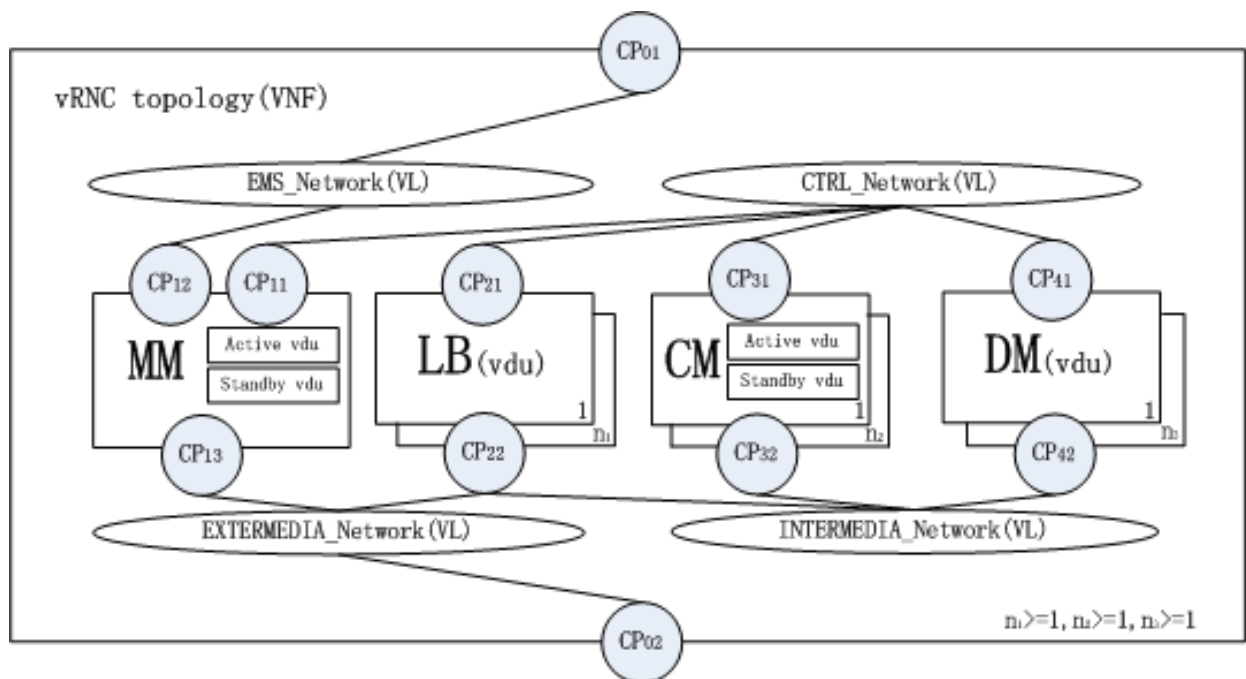

Fig. 4.1: vRNC Topology

- vRNC includes four networks: EMS\_network, CTRL\_network, Intermedia\_network and extermedia\_network;
- vRNC includes four node types: MM, LB, CM and DM;
- MM: Stands for Maintain Module, which links to EMS\_network, CTRL\_network and extermedia\_network. It composes of active vdu and standby vdu.
- CM: Stands for Control Module, which links to CTRL\_network and intermedia\_network. All CM nodes form resource pool and each node composes of active vdu and standby vdu.
- DM: Stands for Data Module, which links to CTRL\_network and intermedia\_network. All DM nodes form resource pool and each node is a vdu.
- LB: Stands for LineCard Module, which links to CTRL\_network and intermedia\_network and extermedia\_network. All LB nodes form resource pool and each node is a vdu.

## 4.1 2. vRNC Definition

The files dependency and corresponding specification of vRNC definition are shown below: Fig. 4.2

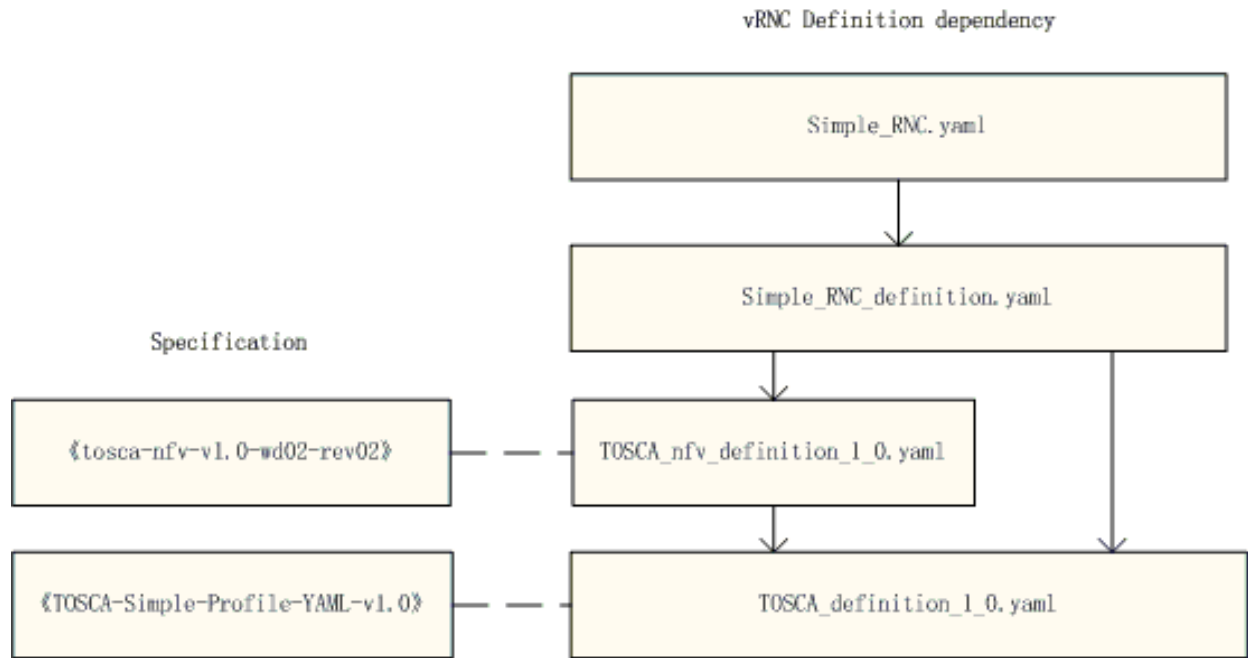

Fig. 4.2: vRNC Definition

- TOSCA\_definition\_1.0.yaml should be the latest version, which is updated by tosca-parser community, but some keywords (such as substitution\_mappings) in the corresponding standard of “TOSCA-simple-profile-YAML-v1.0” is not supported.
- TOSCA\_nfv\_definition\_1.0.yaml is a new file, and not implemented in code, and the corresponding standard of “tosca-nfv-v1.0-wd02-rev02” is not complete now.